

RouterBOARD 133 Series

User's Manual

Rev. B (12-Mar-2007)

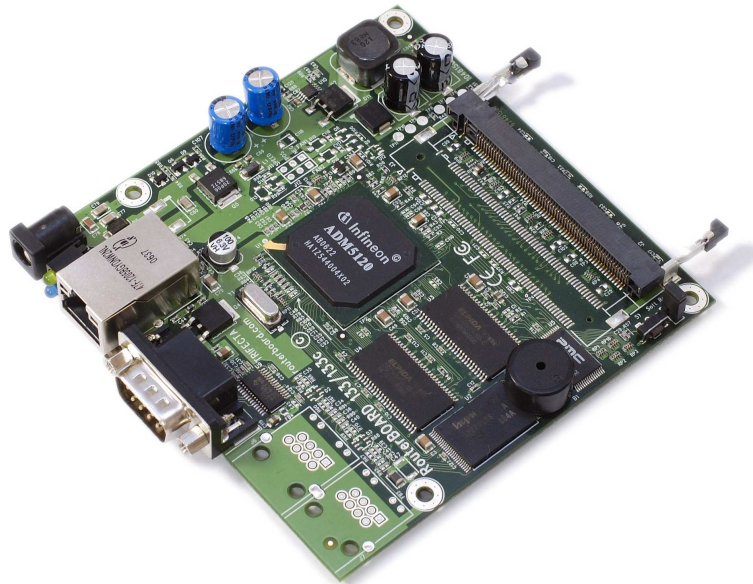

Copyright

Copyright © 2003-2007 MikroTiks SIA. This manual contains information protected by copyright law. No part of it may be reproduced or transmitted in any form without prior written permission from the copyright holder.

Trademarks

RouterBOARD, RouterOS, RouterBOOT and MikroTik are trademarks of MikroTiks SIA. All trademarks and registered trademarks appearing in this manual are the property of their respective holders.

Limited Warranty

Hardware. MikroTiks SIA warrants all RouterBOARD 133 series equipment for the term of one year from the shipping date to be free of defects in materials and workmanship under normal use and service. All parts will be repaired or replaced with similar or functionally equivalent parts by MikroTiks SIA during the warranty term, except in case the returned parts have mechanical, electrical or other accidental or intended damages caused by improper use or due to wind, rain, fire or other acts of nature.

Parts (or systems) must be shipped pre-paid to our facility in Riga, Latvia. All items must have a Return Material Authorization (RMA) which you can get by contacting us via email, telephone or fax. RMA must be printed, signed, and enclosed with the shipment, also the RMA number must be written on the package itself. Parts sent without following the proper procedure will be treated as those not to be repaired or replaced due to the above mentioned conditions. Items proved to be free of defects in our lab will be returned to the customer at the customer's expense. Those that do meet the warranty repair requirements will be repaired or replaced, and returned to the customer's location at our expense, extending the warranty term for the time the items are being shipped to and from our facility and replaced or repaired.

Manual. This manual is provided "as is" without a warranty of any kind, expressed or implied, including, but not limited to, the implied warranty of merchantability and fitness for a particular purpose. The manufacturer has made every effort to ensure the accuracy of the contents of this manual, however, it is possible that it may contain technical inaccuracies, typographical or other errors. No liability is assumed for any inaccuracy found in this publication, nor for direct or indirect, incidental, consequential or other damages that may result from such an inaccuracy, including, but not limited to, loss of data or profits. Please report any inaccuracies found to docs@mikrotik.com.

Table of Contents

Copyright	1
Trademarks	1
Limited Warranty	1
System Board View	3
System Board Layout	3
Specifications	4
Block Diagram	4
Hardware Guide	5
Memory and Storage Devices	5
Onboard Memory	5
Onboard NAND Storage Device	5
Extension Slots	5
MiniPCI Slots	5
Input/Output Ports	5
LAN1 Port with PoE	5
LAN2 Port (RB133 only)	5
LAN3 Port (RB133 only)	5
DB9 Serial Port	5
Fan Connectors (RB133 only)	5
LEDs	6
Power LED	6
User LED	6
User's Guide	6
Assembling the Hardware	6
Powering	6
Booting options	6
Onboard NAND Storage Device	6
Booting from network	7
Operating System Support	7
System Architecture	7
MikroTik RouterOS	7
RouterBOOT	7
Boot Loader Configuration	7
Configurable Options	8
Boot Loader Upgrading	8
Appendix	9
Connector Index	9
Jumper Index	10
Button Index	10
Ethernet Cables	10
Serial Null-modem (Console) Cable with Loopback	10
RouterBOARD 133 dimensions	11
RouterBOARD 133c dimensions	12

System Board View

RB133:

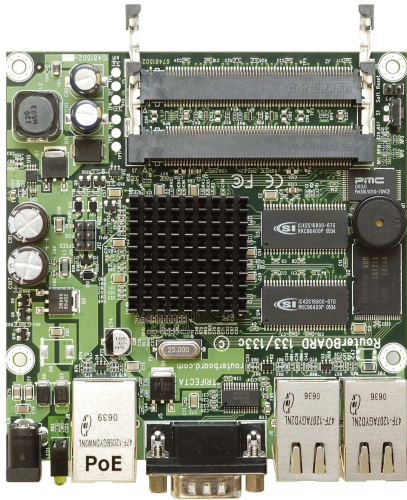

Top view

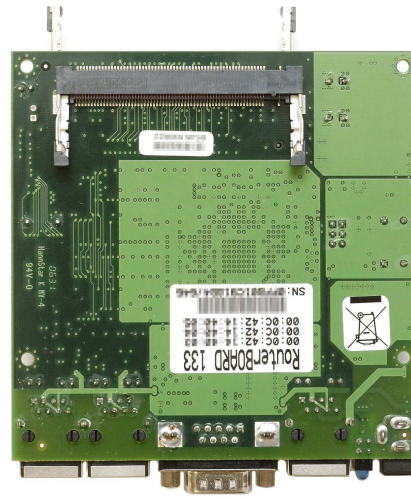

Bottom view

RB133c:

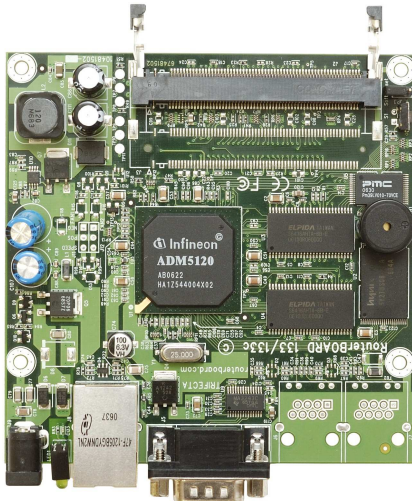

Top view

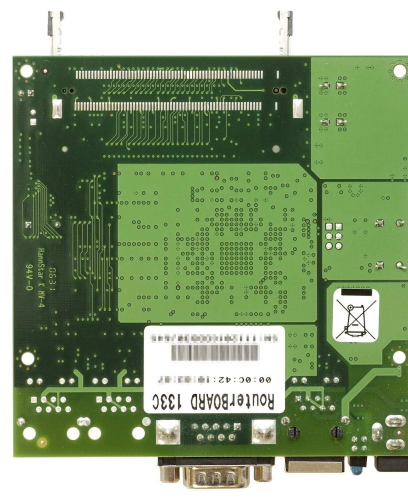

Bottom view

System Board Layout

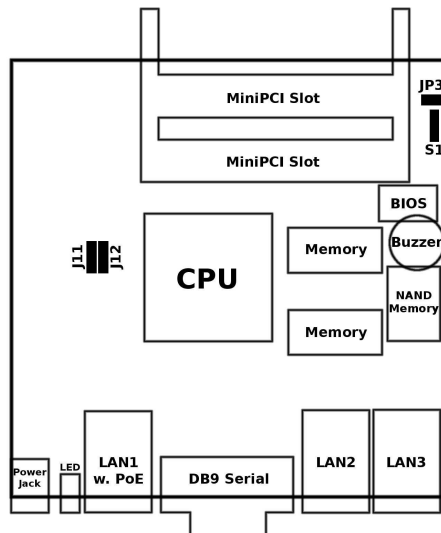

Note: on the other side of the board, there is only a MiniPCI connector, so no layout diagram shown.

Specifications

	RouterBOARD 133	RouterBOARD 133c
CPU	MIPS32 4Kc based 175MHz embedded processor	
Memory	32MB SDRAM onboard memory	16MB SDRAM onboard memory
Boot loader	RouterBOOT, 1Mbit Flash chip	
Data storage	64 or 128MB onboard NAND memory chip	
Ethernet	Three 10/100 Mbit/s Fast Ethernet ports supporting Auto-MDI/X	One 10/100 Mbit/s Fast Ethernet port supporting Auto-MDI/X
MiniPCI slot	Three MiniPCI Type IIIA/IIIB slots	One MiniPCI Type IIIA/IIIB slots
Serial port	One DB9 RS232C asynchronous serial port	
LEDs	Power and User LED	
Speaker	Mini PC-Speaker	
Power options	Power over Ethernet: 12..28V DC (except power over datalines) Power jack: 9..28V DC	
Fan control	Two DC fan power output headers with rotation sensor and automatic fan switching (maximum output current - 500mA total)	None
Dimensions	11.7 cm x 10.5 cm (4.61 in x 4.13 in)	
Weight	115 g (4.06 oz)	79 g (2.79 oz)
Temperature	Operational: -20°C to +65°C (-4°F to 149°F)	
Humidity	Operational: up to 70% relative humidity (non-condensing)	
Power consumption	3-4W without extension cards, maximum – 20W (10W output to extension cards)	

Block Diagram

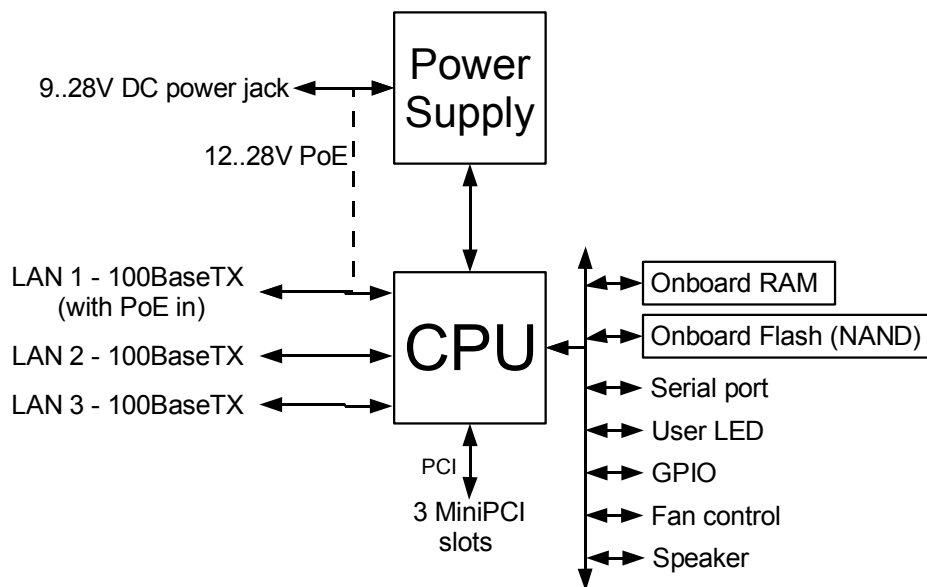

Hardware Guide

Memory and Storage Devices

Onboard Memory

The boards are equipped with 16 MB (RB133c) or 32 MB (RB133) SDRAM onboard memory, depending on build version.

Onboard NAND Storage Device

The boards are equipped with one 64 or 128MB NAND nonvolatile memory chip.

Extension Slots

MiniPCI Slots

Depending on the build option, the board has either one (RB133c) or three (RB133) MiniPCI Type IIIA slots with 3.3V only power signaling. They also accept MiniPCI Type IIIB standard cards. The board has been tested to operate with 3 Ubiquity SR2 high power cards if ambient temperature and adequate cooling is ensured.

Supplied power for the extension cards (excluding CPU and onboard Ethernet ports):

+3.3V: 3.0A max

Input/Output Ports

LAN1 Port with PoE

This Fast Ethernet port is recognized as the first LAN interface. It is compatible with passive (non-standard) Power over Ethernet. The board accepts voltage input from 12 to 28 V DC. It is suggested to use higher voltages for power over long cables because of better efficiency (less power is lost in the cable itself and power supply is more efficient).

See **Connector Index** for pinout of the standard cable required for PoE. All cables made to EIA/TIA 568A/B cable specifications will work correctly with PoE. Note that this port supports automatic cross/straight cable correction (Auto MDI/X), so you can use either straight or cross-over cable for connecting to other network devices.

LAN2 Port (RB133 only)

This Fast Ethernet port is recognized as the second LAN interface. This port does not support Power over Ethernet.

All cables made to EIA/TIA 568A/B cable specifications will work correctly (see **Connector Index** for pinout). Note that this port supports automatic cross/straight cable correction (Auto MDI/X), so you can use either straight or cross-over cable for connecting to other network devices.

LAN3 Port (RB133 only)

This Fast Ethernet port is recognized as the third LAN interface. This port does not support Power over Ethernet.

All cables made to EIA/TIA 568A/B cable specifications will work correctly (see **Connector Index** for pinout). Note that this port supports automatic cross/straight cable correction (Auto MDI/X), so you can use either straight or cross-over cable for connecting to other network devices.

DB9 Serial Port

The RS232C standard male DB9 asynchronous serial port may be used for initial configuration, or for attaching a modem or any other RS232 serial device. TxD (pin 3) of this port has -5V DC power when idle. RTS and DTR signals are not connected. This implementation may not be considered to support full hardware flow-control, so software flow-control (XON/XOFF) should be used.

Fan Connectors (RB133 only)

You can connect up to two fans to the RouterBOARD, but only one of them will work at the same time. They

will receive the same voltage as the board itself (**CAUTION:** you may damage the fans if the input voltage of the board is out of fans' operating range). The board supports fan speed feedback signaling. RouterOS will change the active fan, if the current active one is not rotating.

LEDs

Power LED

Power LED is on when the board is powered.

User LED

User LED may be programmed at user's option. It is lit by default when the board starts up, then it is turned off when the bootloader runs kernel.

User's Guide

Assembling the Hardware

First to use the board:

- Insert MiniPCI cards and connect antenna wires, if needed;
- Install the board in a case;
- Connect other peripherals and cables.

You can also order a pre-assembled system with RouterBOARD and extension cards of your choice already installed in a case.

Powering

Power options:

- **J9** power jack:
9..28V DC (cut-off voltage - 30V)
- Power over Ethernet (PoE) on the **J8** LAN1 Ethernet port:
9..28V DC (18..28 V suggested; cut-off voltage - 30V) non-standard PoE powering support

The board has a direct-input power jack **J9** (5.5mm outside and 2mm inside diameter, female, pin positive plug) and can as well be powered with PoE. All power inputs are always active, but only one should be used at the same time.

RouterBOARD 133 series boards are equipped with a reliable 20W onboard power supply with overvoltage protection. 9..28 V DC input voltages are accepted, but when powered over long cables, it is suggested to use at least 18V. The system is tested with 24V solar/wind/RV systems with 27.6 charge voltage. Overvoltage protection starts from about 30V (up to 100V), so the board will not be damaged if connected to a 48 or 60 V power line.

RouterBOARD 133 series boards are compatible with non-standard (passive) Power over Ethernet injectors (except power over datalines) and accept powering over up to 100m (330 ft) long Ethernet cable connected to the Ethernet port (**J8**). The board **does not** work with IEEE802.3af compliant 48V power injectors.

The maximum output of the power supply to the extension cards is normally at about 3.0A, but the efficiency is decreased on lower voltages, so it is about 2-2.5A when powered from 12V DC.

Booting options

First, RouterBOOT loader is started. It displays some useful information on the onboard RS232C asynchronous serial port, which is set to 115200bit/s, 8 data bits, 1 stop bit, no parity by default. The loader may be configured to boot the system from the onboard NAND module or from Ethernet network. See the respective section of this manual for how to configure booting sequence and other boot loader parameters.

Onboard NAND Storage Device

The RouterBOARD may be started from the onboard NAND storage chip. As there is no partition table on the device, the boot loader assumes the first 4MiB form a YAFFS filesystem, and executes the file called "kernel" stored in the root directory on that partition. It is possible to partition the rest of the medium by patching the kernel source.

Booting from network

Network boot works similarly to PXE or EtherBoot protocol, and allows you to boot a RouterBOARD 133 series computer from an executable image stored on a TFTP server. It uses BOOTP or DHCP (configurable in boot loader) protocol to get a valid IP address, and TFTP protocol to download an executable (ELF) kernel image combined with the initial RAM disk (inserted as an ELF section) to boot from (the TFTP server's IP address and the image name must be sent by the BOOTP/DHCP server).

To boot the RouterBOARD computer from Ethernet network you need the following:

- An ELF kernel image for the loader to boot from (you can embed the kernel parameters and initrd image as ELF sections called *kernparm* and *initrd* respectively)
- A TFTP server which to download the image from
- A BOOTP/DHCP server (may be installed on the same machine as the TFTP server) to give an IP address, TFTP server address and boot image name

See the RouterBOOT section on how to configure loader to boot from network.

Note that you must connect the RouterBOARD you want to boot, and the BOOTP/DHCP and TFTP servers to the same broadcast domain (i.e., there must not be any routers between them).

Operating System Support

System Architecture

RouterBOARD 133 series embedded boards are fully compatible with the standard MIPS32 architecture with PCI bus.

CPU. RouterBOARD 133 series has MIPS32 little-endian based embedded processor using MIPS 4Kc CPU core. It is fully binary-compatible with all software developed for MIPS32 little-endian (mipsel) instruction set architecture. The MIPS 4Kc core includes TLB Memory Management Unit and does not include Float Point Unit (so it is optimized for integer operations).

Ethernet. RouterBOARD 133 series has three onboard Ethernet ports controlled by ADMtek MAC/PHY embedded in the CPU.

MikroTik RouterOS

MikroTik RouterOS, starting from version 2.9.38 (RouterBOARD 100/500 series edition), is fully compatible with RouterBOARD 133 series embedded boards.

RouterBOOT

The RouterBOOT firmware (also referred as "boot loader" here) provides minimal functionality to boot an Operating System. It supports serial console via the onboard serial port at the boot time. The loader supports booting from the onboard NAND device and from a network server (see the respective section for details on this protocol).

Boot Loader Configuration

Loader parameters may be configured through the onboard RS232C DB9 asynchronous serial interface. To connect to it, use a standard null-modem cable. By default, the port is set to 115200bit/s, 8 data bits, 1 stop bit, no parity. **Note** that the device does not fully implement the hardware (RTS/CTS) flow control, so it is suggested to try to disable hardware flow control in the terminal emulation program in case the serial console does not work as expected, and if it does not help, make a new cable using the pinout given in the Appendix.

To enter the loader configuration screen, press any key (or only [Delete] key (or [Backspace] key – see the note for the respective configurable option), depending on the actual configuration) just after the loader is asking for it:

```
RouterBOOT booter 2.5
```

```
RouterBoard 133
```

```
CPU frequency: 175 MHz
```

```
Memory size: 32 MB
```

```
Press any key within 2 seconds to enter setup
```

```

RouterBOOT-2.5
What do you want to configure?
  d - boot delay
  k - boot key
  s - serial console
  o - boot device
  u - cpu mode
  r - reset configuration
  e - format nand
  g - upgrade firmware
  i - board info
  p - boot protocol
  t - do memory testing
  x - exit setup
your choice:

```

To select a menu point, press the key written at the beginning of this line. Pressing [Enter] selects the option marked with '*'.

Configurable Options

boot delay – how much time to wait for a key stroke while booting (1..9 seconds; **2 second** by default).

boot key – which key will cause the loader to enter configuration mode during **boot delay** (any key | <Delete> key only; **any key** by default). Note that in some serial terminal programs, it is impossible to use the [Delete] key to enter the setup – in this case it might be possible to do this with the [Backspace] key.

serial console – to configure initial serial console bitrate (1200 | 2400 | 4800 | 9600 | 19200 | 38400 | 57600 | 115200; **115200** bps by default).

boot device – initial boot device (boot over Ethernet | boot from NAND | boot Ethernet once, then NAND; **boot from NAND** by default). You can also select **boot chosen device** option to boot from the device selected immediately, without saving the setting.

cpu mode – whether to enter CPU suspend mode on WAIT instruction (power save | regular; **power save** by default). Most OSs use WAIT instruction during CPU idle cycle. When CPU is in suspend mode, it consumes less power, but in low-temperature conditions (below 0°C) it is recommended to choose regular mode, so that overall system temperature would be higher.

reset configuration – whether to reset all the boot loader settings to their respective default values (yes | no; **no** by default).

format nand – perform a low-level NAND format. During this operation, all previously marked bad sectors are retested to find out if they are faulty indeed.

upgrade firmware – receive a new boot loader image using XModem protocol over serial line or using DHCP/BOOTP and TFTP protocols through the Ethernet network (upgrade firmware over ethernet | upgrade firmware over serial port).

board info – prints the serial number, boot loader version, CPU frequency, memory size and MAC addresses of the onboard Ethernet ports

boot protocol – network booting protocol (bootp protocol | dhcp protocol; **bootp protocol** by default).

do memory testing – performs a full memory test.

Boot Loader Upgrading

The boot loader is needed to initialize all the hardware and boot the system up. Newer loader versions might have support for more hardware, so it's generally a good idea to upgrade the loader once a newer version is available. You can upgrade the loader through the onboard serial port using XModem protocol (programs available for all major OSs). For example, you can use HyperTerminal for Windows or Minicom for Linux to upload the boot loader. Alternatively if you have a DHCP/BOOTP and TFTP servers available, you can specify the loader image as a boot image and choose the **bios upgrade over ethernet** option in the boot loader configuration menu. The loader will get the image from the TFTP server and upgrade itself. The most current loader image is available for download on www.routerboard.com.

The boot loader upgrading is supported also from MikroTik RouterOS. The procedure is described in the MikroTik RouterOS manual.

Appendix

Connector Index

J2	MiniPCI Type type IIIA/B connector 1 (top side)
J3	MiniPCI Type type IIIA/B connector 2 (top side; RB133 only)
J4	MiniPCI Type type IIIA/B connector 3 (bottom side; RB133 only)
J5	RS232C male DB9 serial port
	1 DCD (Data Carrier Detect)
	2 RxD (Receive Data)
	3 TxD (Transmit Data)
	5 GND
	6 DSR (Data Set Ready)
	8 CTS (Clear to Send)
J6	RJ45 Fast Ethernet 100Base-TX port LAN2 (no PoE; RB133 only)
	1 Data TX+
	2 Data TX-
	3 Data RX+
	6 Data RX-
J7	RJ45 Fast Ethernet 100Base-TX port LAN3 (no PoE; RB133 only)
	1 Data TX+
	2 Data TX-
	3 Data RX+
	6 Data RX-
J8	RJ45 Fast Ethernet 100Base-TX port LAN1 with passive PoE extension
	1 Data TX+
	2 Data TX-
	3 Data RX+
	4 PoE power +
	5 PoE power +
	6 Data RX-
	7 PoE power -
	8 PoE power -
J9	Power jack (9..28 V DC, positive contact is the central pin)
J11	DC Fan 1 connector (RB133 only)
	1 GND
	2 +9..+30 V DC (same as input voltage)
	3 Rotation speed feedback
J12	DC Fan 2 connector (RB133 only)
	1 GND
	2 +9..+30 V DC (same as input voltage)
	3 Rotation speed feedback

Jumper Index

JP3	User-defined jumper (GPIO3)
-----	-----------------------------

Button Index

S1	Software reset button (GPIO7)
----	-------------------------------

Ethernet Cables

RJ45 Pin	Color	Function	RJ45 pin for Straight cable (MDI, EIA/TIA568A)	RJ45 pin for Crossover cable (MDI-X, EIA/TIA568B)
1	Green	TX+ Data	1	3
2	Green/White	TX- Data	2	6
3	Orange	RX+ Data	3	1
4	Blue	-	4	4
5	Blue/White	-	5	5
6	Orange/White	RX- Data	6	2
7	Brown	-	7	7
8	Brown/White	-	8	8

Serial Null-modem (Console) Cable with Loopback

DB9f	Function	DB9f	DB25f
1 + 4 + 6	CD + DTR + DSR	1 + 4 + 6	6 + 8 + 20
2	RxD	3	2
3	TxD	2	3
5	GND	5	7
7 + 8	RTS + CTS	7 + 8	4 + 5

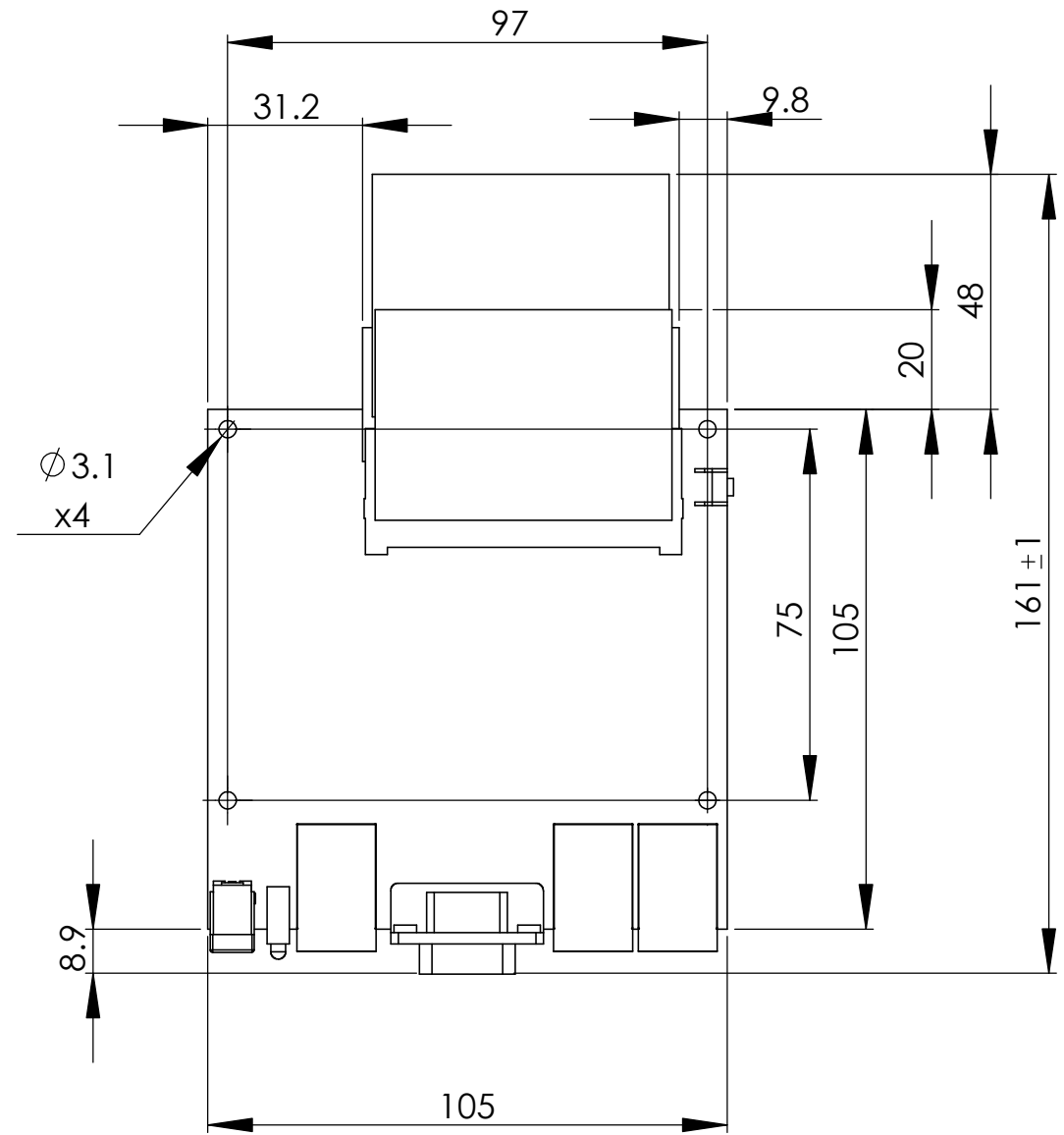
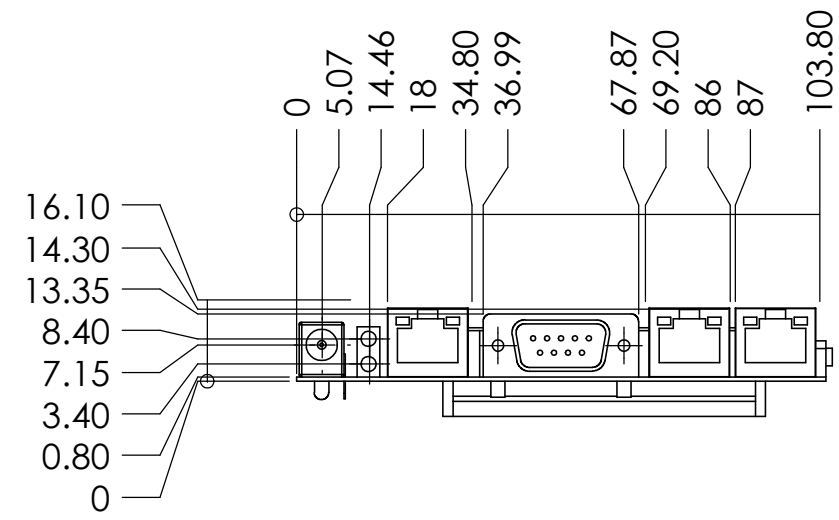
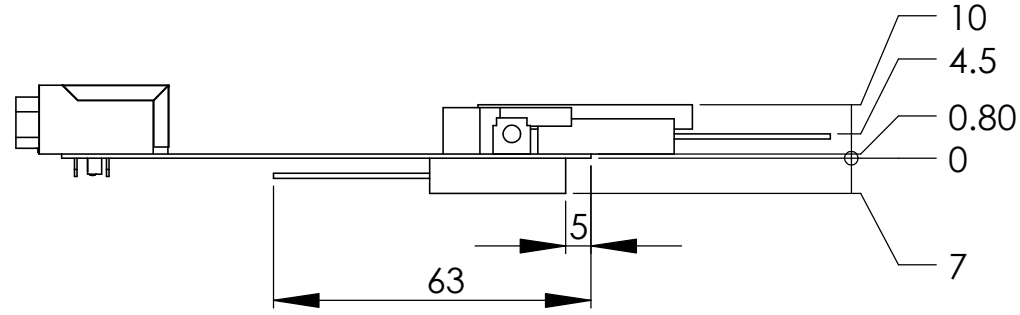

1. Unspecified R ≤ 1
 2. Unspecified tolerances: DIN7168/FINE
 except p.3:

Tolerance		
Nominal	IT12	
>	≤	IT12
6	30	0.1
30	120	0.3
120	315	0.4
315	1000	0.6
1000	2000	1.0

External: -IT12
 Internal: +IT12
 Others: ±IT12/2

3. Hole coordinates with unspecified tolerances
 Hole pattern $\phi \phi 0,3$ for all coordinative dim-s;
 countersunks - $\phi \phi 0,1$

Do not scale drawing		Finish:		Scale 1:1.5		Mass:	
				Material:			
		Date		Name		Description:	
		Drawn. 13.09.06		Veiders		Routerboard 133 dimensions	
		Check:					
		Approv:					
				Drawing code:		A3	
				RB133		sheet 1 of 1	
						Printed: 06.12.06	

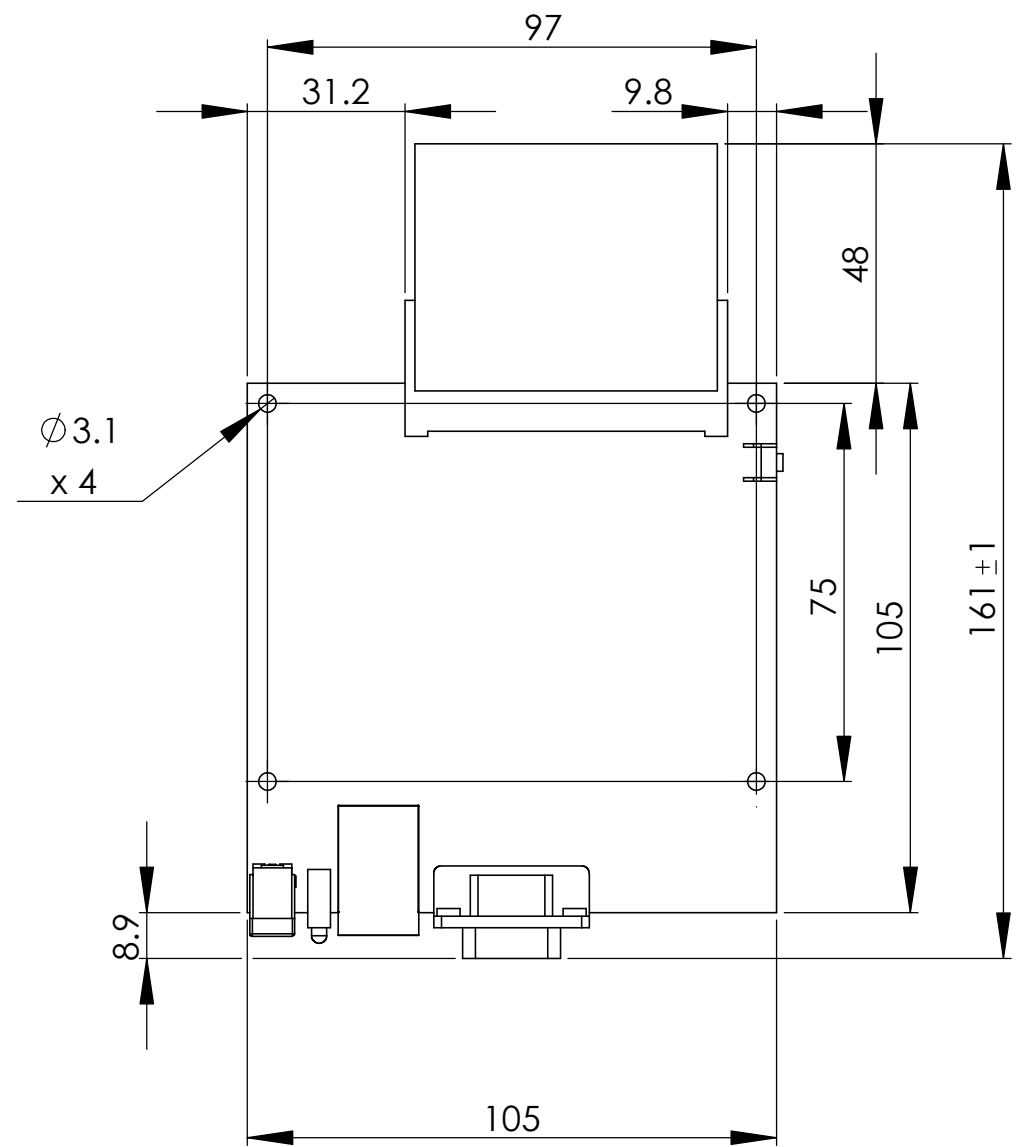
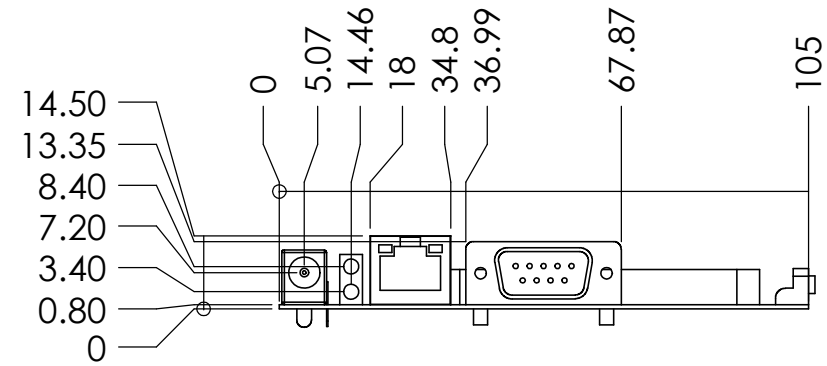
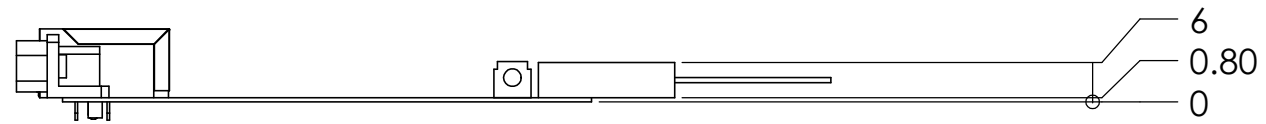

1. Unspecified R ≤ 1
 2. Unspecified tolerances: DIN7168/FINE
 except p.3:

Tolerance		
Nominal	IT12	
>	≤	IT12
6	30	0.1
30	120	0.3
120	315	0.4
315	1000	0.6
1000	2000	1.0

External: -IT12
 Internal: +IT12
 Others: ±IT12/2

3. Hole coordinates with unspecified tolerances
 Hole pattern $\phi \phi 0,3$ for all coordinative dim-s;
 countersunks - $\phi \phi 0,1$

Do not scale drawing		Finish:		Scale 1:1.5		Mass:	
				Material:			
		Date		Name		Description:	
		Drawn. 06.12.06		Veiders		Routerboard 133c dimensions	
		Check:					
		Approv:					
				Drawing code:		A3	
				RB133c		sheet 1 of 1	
						Printed: 06.12.06	